

COMMON

- Added accessories can affect a motorcycle's stability, performance and safe riding speed.

ACCESSORY SOCKET

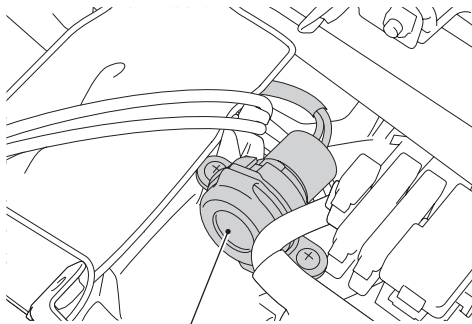

ACCESSORY SOCKET

- The maximum power rating of connected accessories is 24W (12V, 2A).
- Use accessories with engine running to avoid discharging the battery.
- Do not use a cigarette lighter, as this can cause a malfunction.
- Cover the socket with the cap when the accessory socket is not used to prevent entry of foreign objects.
- Carefully secure any connected devices, as vibrations may cause them to shift unexpectedly.

FRONT FENDER PANEL

FRONT FENDER PANEL

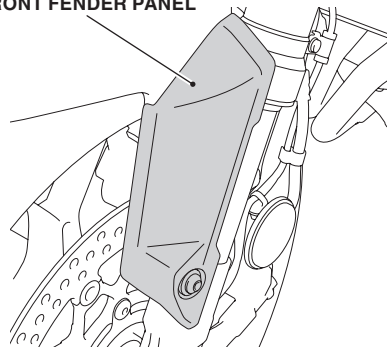

- When this accessory becomes dirty, rinse it thoroughly with cool water to remove loose dirt, then wipe with a clean cloth or sponge. Do not use a brush to clean this accessory as it may scratch the surface.
- Never use organic solvents such as gasoline, thinner and benzine to clean this accessory. Also do not use acid or alkaline cleaners to clean this accessory. Wipe up spilled brake or battery fluid at once as they may damage the surface.

FRONT VISOR

FRONT VISOR

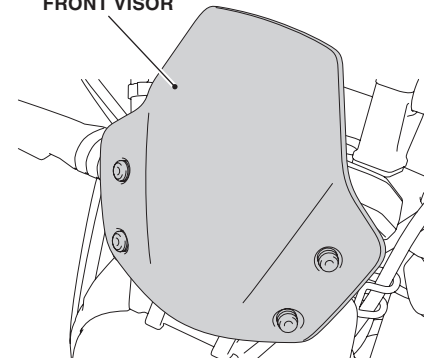

- When this accessory becomes dirty, rinse it thoroughly with cool water to remove loose dirt, then wipe with a clean cloth or sponge. Do not use a brush to clean this accessory as it may scratch the surface.
- Never use organic solvents such as gasoline, thinner and benzine to clean this accessory. Also do not use acid or alkaline cleaners to clean this accessory. Wipe up spilled brake or battery fluid at once as they may damage the surface.
- Handle this accessory with care. It can be damaged when it is bent excessively or is subject to strong shock or impact.

GRIP HEATER

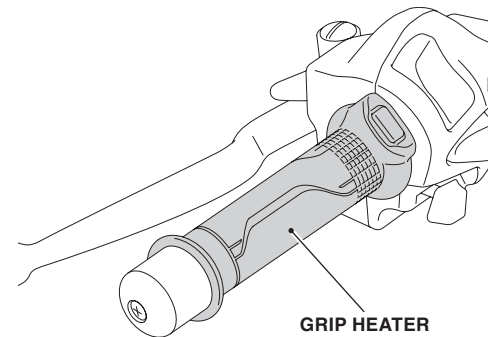

GRIP HEATER

HOW TO USE THE GRIP HEATER

- For operating instruction, refer to the Owner's Manual of the grip heater kit.

CB650RA/CBR650RA

Genuine Accessory User's Guide

HIGH WIND SCREEN

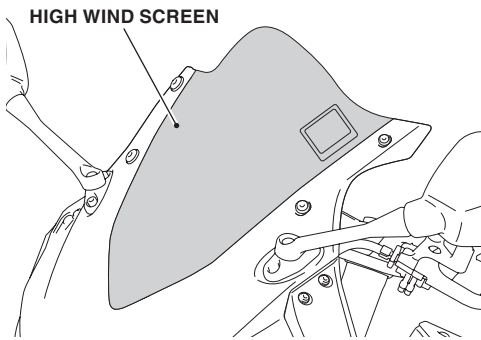

- Replace this accessory with a new one if it is damaged or discolored excessively.
- When this accessory becomes dirty, rinse it thoroughly with cool water to remove loose dirt, then wipe with a clean cloth or sponge. Do not use a brush to clean this accessory as it may scratch the surface.
- Never use organic solvents such as gasoline, thinner and benzine to clean this accessory. Also do not use acid or alkaline cleaners to clean this accessory. Wipe up spilled brake or battery fluid at once as they may damage the surface.
- If the motorcycle is left covered for an extended period of time, park in the shade. Parking a covered motorcycle in direct sunlight can cause the high wind screen to deform due to heat buildup under the cover.
- Handle this accessory with care. It can be damaged when it is bent excessively or is subject to strong shock or impact.
- Select a firm, level surface when you park the motorcycle. Also bear in mind that strong wind can cause the motorcycle to topple to the ground.

QUICK SHIFTER

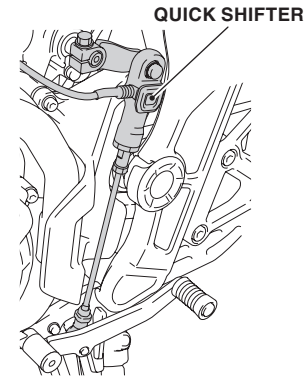

- Do not disassemble the quick shifter.
- If you cannot shift up by operating the quick shifter during acceleration (Engine speed is more than 1,500 rpm), a failure may occur. Please contact your Honda dealer for assistance.
- If the gear position display is not normal, the shift feeling may change.
- When the shift change do not operate normally, the shift change by clutch operation can be operated.

OPERATING INSTRUCTIONS

- **This accessory enable the shifting up without clutch operation when shifting up during acceleration (Engine speed is more than 1,500 rpm).**

<Shift up>

- Shifting up without clutch and throttle operations.

<Shift down>

- Make sure to operate clutch to shift down.

METER VISOR

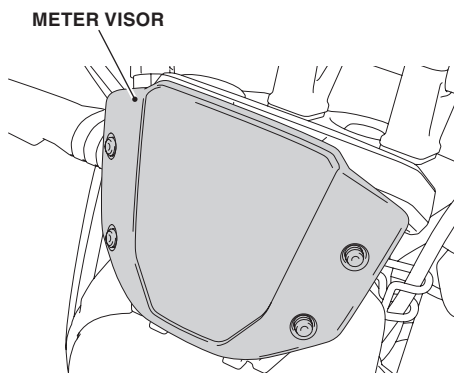

- When this accessory becomes dirty, rinse it thoroughly with cool water to remove loose dirt, then wipe with a clean cloth or sponge. Do not use a brush to clean this accessory as it may scratch the surface.
- Never use organic solvents such as gasoline, thinner and benzine to clean this accessory. Also do not use acid or alkaline cleaners to clean this accessory. Wipe up spilled brake or battery fluid at once as they may damage the surface.
- Handle this accessory with care. It can be damaged when it is bent excessively or is subject to strong shock or impact.

CB650RA/CBR650RA

Genuine Accessory User's Guide

REAR SEAT BAG



- The weight of the cargo must not exceed the following maximum weight capacity:
Rear seat bag 4.0 kg (8.8 lb)
- Be sure that the rear seat bag is installed securely before riding.
- Before riding, close the rear seat bag.
- The rear seat bag is not perfectly watertight, and water may enter when it rains, etc.
- Do not store valuables or fragile articles in the rear seat bag.
- To prevent burns, allow the engine, exhaust system, radiator, etc., to cool before installing and removing the accessory.
- When washing the motorcycle and when leaving the motorcycle, remove the rear seat bag.
- Do not let anybody ride on the rear seat bag and do not place luggage onto it.
- Never use organic solvents such as gasoline, thinner and benzine to clean this accessory. Also do not use acid or alkaline cleaners to clean this accessory.

Wipe up spilled brake or battery fluid at once as they may damage the surface.

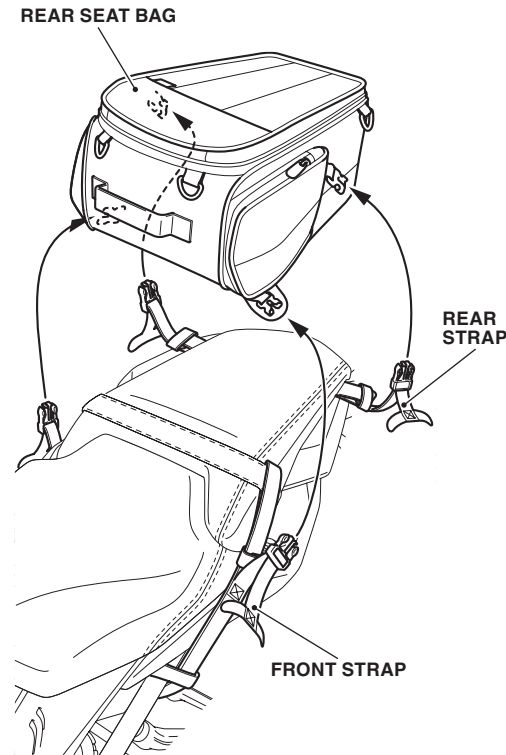

HOW TO INSTALL THE REAR SEAT BAG

1. Install the rear seat bag as shown.

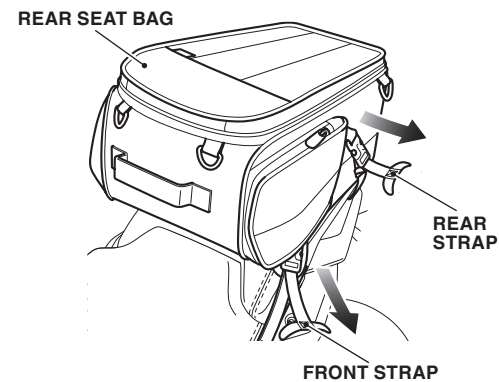

2. Tighten the straps while adjusting the balance between the right and left sides of the rear seat bag as shown.
 - Repeat on the right side.
 - Secure well by pulling the straps tight.
3. Secure the front straps end as shown.

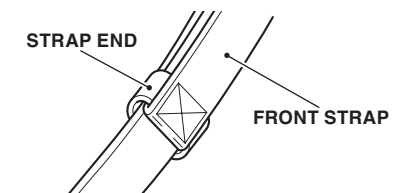

CB650RA/CBR650RA

Genuine Accessory User's Guide

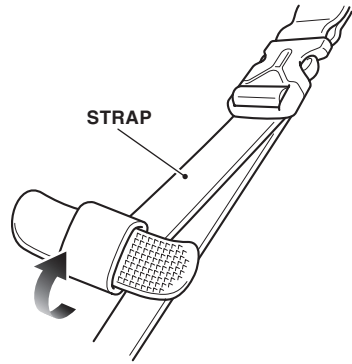

4. Wind the strap as shown.
5. Secure the strap end as shown.

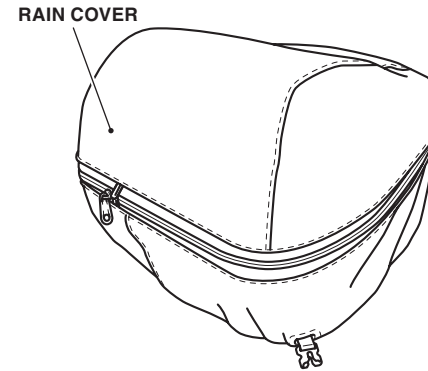
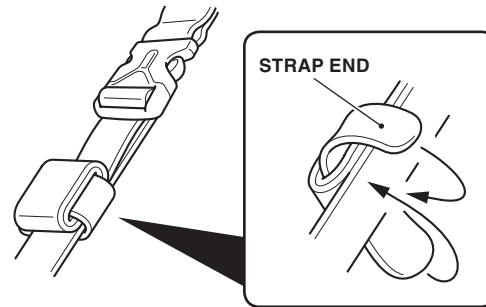

2. Temporarily release the buckles and pass them through the rain cover holes as shown.

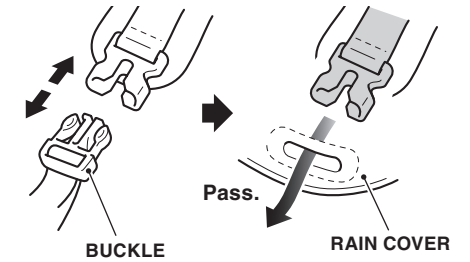

3. Cover the rain cover as shown.

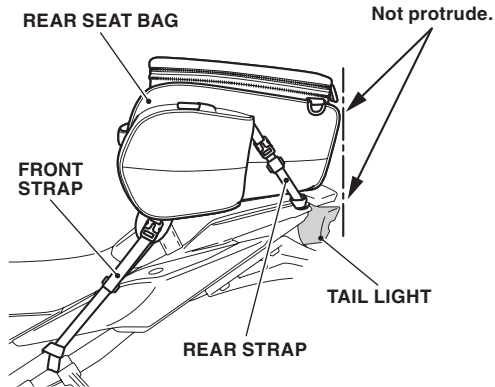

6. Secure the other straps in the same manner.
7. Make sure that the rear seat bag does not protrude to the rear of the tail light as shown.
 - If the rear seat bag protrudes, adjust the tensions of front strap and rear strap.

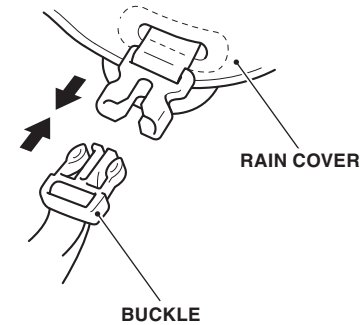

4. Lock the buckles as shown.

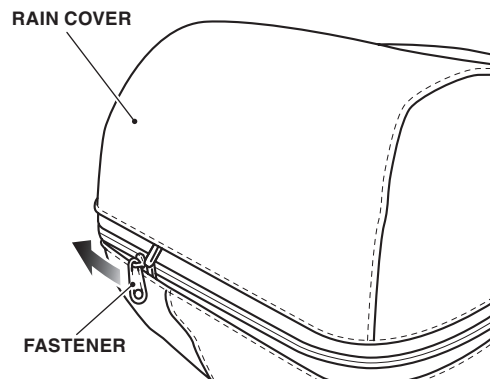

HOW TO USE THE RAIN COVER

1. Open the fastener as shown.
 - Perform this step on extended the rear seat bag.

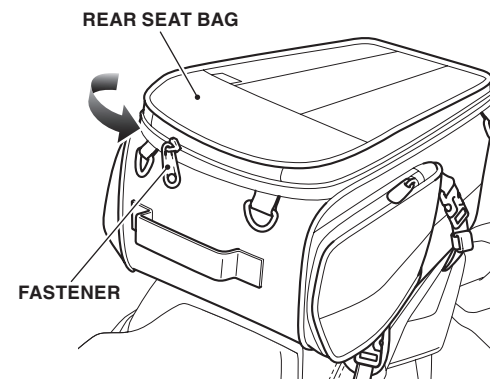

HOW TO USE THE EXTENDED REAR SEAT BAG

1. Open the fastener as shown.

CB650RA/CBR650RA

Genuine Accessory User's Guide

REAR SEAT BAG

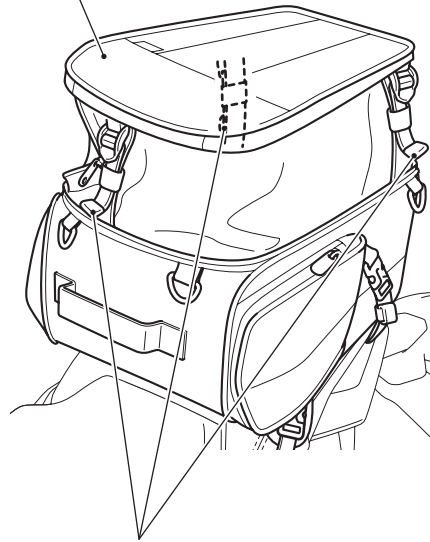

Firmly pull to secure the belts.

2. Pull up the rear seat bag as shown.

SEAT COWL PLATE

SEAT COWL PLATE

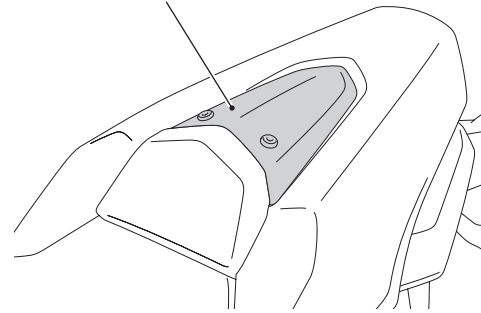

- When this accessory becomes dirty, rinse it thoroughly with cool water to remove loose dirt, then wipe with a clean cloth or sponge. Do not use a brush to clean this accessory as it may scratch the surface.
- Never use organic solvents such as gasoline, thinner and benzene to clean this accessory. Also do not use acid or alkaline cleaners to clean this accessory. Wipe up spilled brake or battery fluid at once as they may damage the surface.

SHROUD COVER

SHROUD COVER

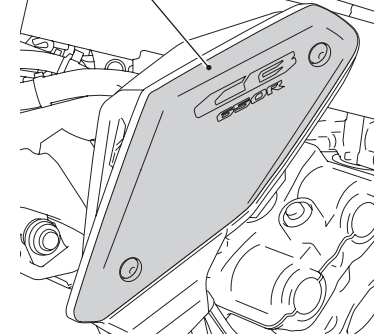

- When this accessory becomes dirty, rinse it thoroughly with cool water to remove loose dirt, then wipe with a clean cloth or sponge. Do not use a brush to clean this accessory as it may scratch the surface.
- Never use organic solvents such as gasoline, thinner and benzene to clean this accessory. Also do not use acid or alkaline cleaners to clean this accessory. Wipe up spilled brake or battery fluid at once as they may damage the surface.

SEAT COWL

SEAT COWL

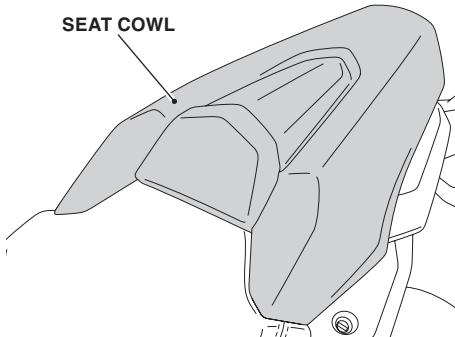

- Do not allow passengers to ride on the seat cowl.
- Do not attach luggage to the seat cowl.
- When this accessory becomes dirty, rinse it thoroughly with cool water to remove loose dirt, then wipe with a clean cloth or sponge. Do not use a brush to clean this accessory as it may scratch the surface.
- Never use organic solvents such as gasoline, thinner and benzene to clean this accessory. Also do not use acid or alkaline cleaners to clean this accessory. Wipe up spilled brake or battery fluid at once as they may damage the surface.

SIDE COVER PANEL

SIDE COVER PANEL

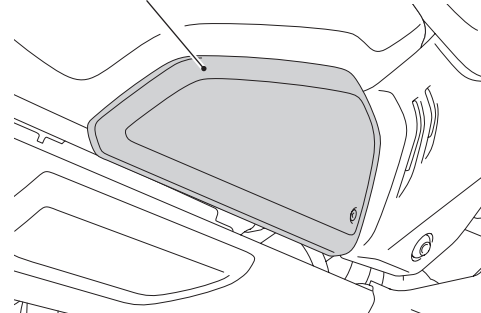

- When this accessory becomes dirty, rinse it thoroughly with cool water to remove loose dirt, then wipe with a clean cloth or sponge. Do not use a brush to clean this accessory as it may scratch the surface.
- Never use organic solvents such as gasoline, thinner and benzene to clean this accessory. Also do not use acid or alkaline cleaners to clean this accessory. Wipe up spilled brake or battery fluid at once as they may damage the surface.

TANK BAG

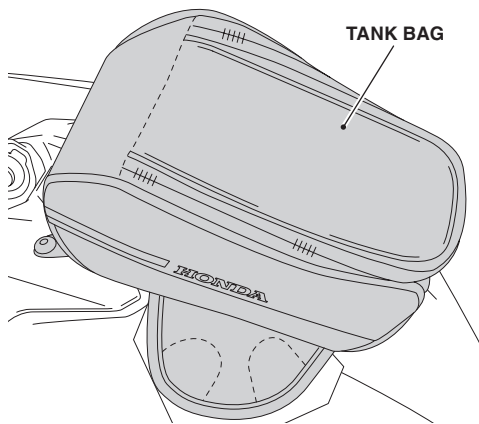

- The weight of the cargo must not exceed the following maximum weight capacity:
Tank bag 1.0 kg (2.2 lb)
 - Be sure that the tank bag is installed securely before riding.
 - Before riding, close the tank bag.
 - The tank bag is not perfectly watertight, and water may enter when it rains, etc.
 - Do not store valuables or fragile articles in the seat bag.
 - When washing the motorcycle and when leaving the motorcycle, remove the tank bag.
 - Before installation, remove all dust, sand, etc. from fuel tank and tank bag, as otherwise the fuel tank may be damaged.
 - Never use organic solvents such as gasoline, thinner and benzine to clean this accessory. Also do not use acid or alkaline cleaners to clean this accessory.
- Wipe up spilled brake or battery fluid at once as they may damage the surface.

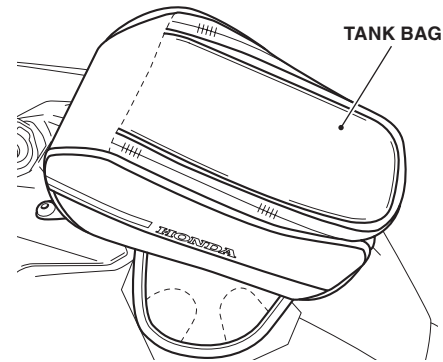

2. Install the tank bag as shown.

RAIN COVER

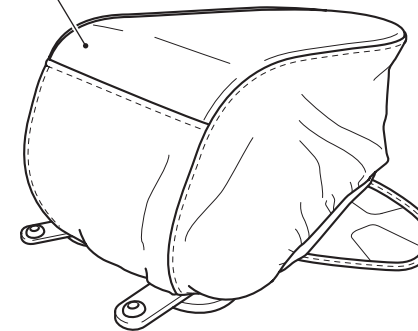

HOW TO USE THE RAIN COVER

1. Put the rain cover on the tank bag as shown.

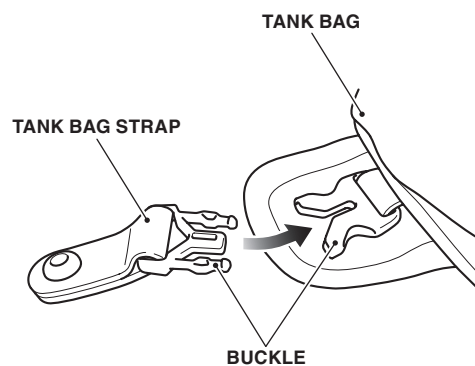

HOW TO INSTALL THE TANK BAG

1. Lock the buckle as shown.
 - Repeat on the right side.

CB650RA/CBR650RA

Genuine Accessory User's Guide

TANK PAD

<CB650RA>

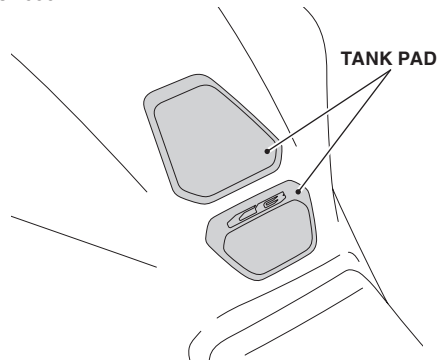

- When this accessory becomes dirty, rinse it thoroughly with cool water to remove loose dirt, then wipe with a clean cloth or sponge. Do not use a brush to clean this accessory as it may scratch the surface.
 - Never use organic solvents such as gasoline, thinner and benzine to clean this accessory. Also do not use acid or alkaline cleaners to clean this accessory.
- Wipe up spilled brake or battery fluid at once as they may damage the surface.

<CBR650RA>

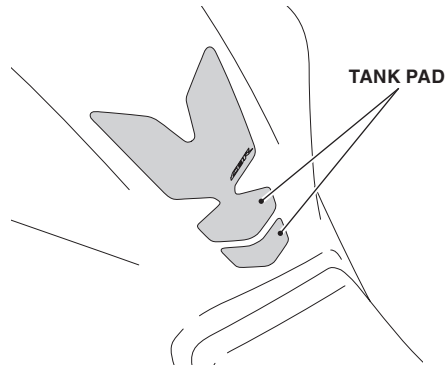

UNDER COWL

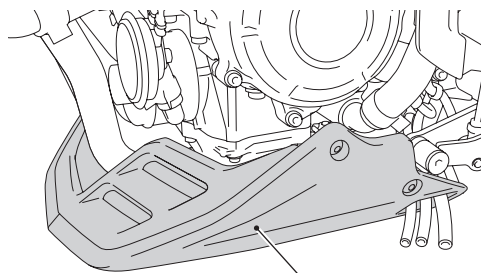

UNDER COWL

- When this accessory becomes dirty, rinse it thoroughly with cool water to remove loose dirt, then wipe with a clean cloth or sponge. Do not use a brush to clean this accessory as it may scratch the surface.
 - Never use organic solvents such as gasoline, thinner and benzine to clean this accessory. Also do not use acid or alkaline cleaners to clean this accessory.
- Wipe up spilled brake or battery fluid at once as they may damage the surface.

WHEEL STRIPE

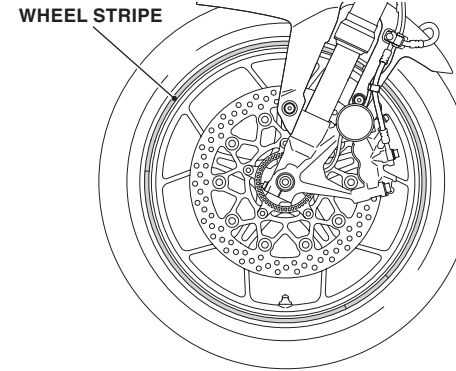

- When this accessory becomes dirty, rinse it thoroughly with cool water to remove loose dirt, then wipe with a clean cloth or sponge. Do not use a brush to clean this accessory as it may scratch the surface.
 - Never use organic solvents such as gasoline, thinner and benzine to clean this accessory. Also do not use acid or alkaline cleaners to clean this accessory.
- Wipe up spilled brake or battery fluid at once as they may damage the surface.
- Do not wash the motorcycle with a high-pressure washer, as this may peel off the wheel stripes.

SAFETY INFORMATION

The following sentences show the label meaning.
Some labels warn you of potential hazards that could cause serious injury.
Others provide important safety information.
Read this information carefully and don't remove the label.

If a label comes off or becomes hard to read, contact your Honda dealer for a replacement.

There is a specific symbol on each label. The meanings of each symbol and label are as follows.



Read the use and care information in installation instructions or genuine accessory user's guide carefully.
Read the **LOAD LIMITS AND GUIDELINES**, and **TYRES** sections in owner's manual.



DANGER (with RED background)

You **WILL** be **KILLED** or **SERIOUSLY HURT** if you don't follow instructions.

WARNING (with ORANGE background)

You **CAN** be **KILLED** or **SERIOUSLY HURT** if you don't follow instructions.

CAUTION (with YELLOW background)

You **CAN** be **HURT** if you don't follow instructions.

Refer to this information for the meanings of the symbols shown on the accessory.

SCREEN WARNING LABEL

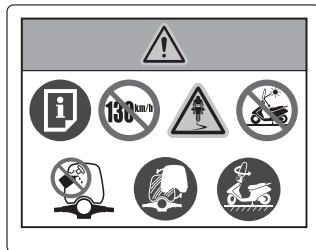

Never ride a motorcycle equipped with accessories and a cargo at speeds above 130 km/h (80 mph).



Added accessories and cargo can reduce a motorcycle's stability, performance and safe riding speed. A motorcycle's stability is influenced by an improper loading, worn or under-inflated tyres, the overall motorcycle condition and environmental conditions.



Do not park the motorcycle with the sun shining on the backside of the unit; the reflection may damage the motorcycle parts.



Never use organic solvents such as gasoline, thinner and benzene to clean this accessory. Also do not use acid or alkaline cleaners to clean.



Replace the windshield if clear vision is obstructed.



Select a firm, level surface when you park the motorcycle.
Also bear in mind that strong wind can cause the motorcycle to fall to the ground.